

You bet this one works!



## » Mobile plunger

The mobile plunger complements the red wine mash tank FO-M perfectly. Some of our customers have several FO-Ms and one mobile plunger that can be used for all of them.

Regulation is carried out either by means of a time- / interval control system or by means of a manual on / off system.

The mobile plunger is equipped with a floating lid for reliable sealing and with the well-tried Speidel immersion system for the gentle mash processing in flexible use. It can be moved with a forklift and needs to be fixed with a fastener made of stainless steel.



New version with  
floating lid

## STANDARD EQUIPMENT FOR MOBILE PLUNGER

- › Floating lid with Speidel's tried and tested plunging system with sealing hose
- › Stainless steel forklift profiles 140x80 mm for transportation, internal dimension shape 134 x 74 mm
- › Stainless steel fastener for fixation
- › Pneumatic cylinder, flange mounted on the reinforced lid, plunger rod and immersion unit made of stainless steel
- › Immersion depth 1,000 mm

## OPTIONS MOBILE PLUNGER

### TIME- / INTERVAL CONTROL SYSTEM

- › Small, electronic control cabinet with time and interval control system, connection 220 V, 50 Hz, IP 44

- › Immersion time and pause time continuously variable

### MANUALLY

- › Operating controlled manually, by pressurised air with on / off switch as low-priced alternative without electricity supply

## SYSTEM REQUIREMENTS MOBILE PLUNGER

### COMPRESSOR

- › Compressor volume at least 90 litres
- › Fan efficiency 500 litres / minimum at 6 bar

- › The compressor's pressurised air must be cleaned with an air preparation unit!
- › We recommend the following air preparation unit: Parker G 1/2" Order No. 90476 (see accessories page 194)

### REQUIRED AIR MASS

- › Immersion depth 1,000 mm  
12.3 litres / lifting force

## MOBILE PLUNGER

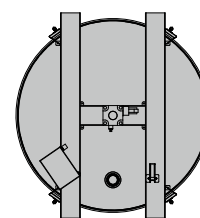
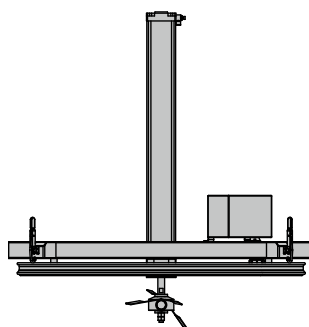
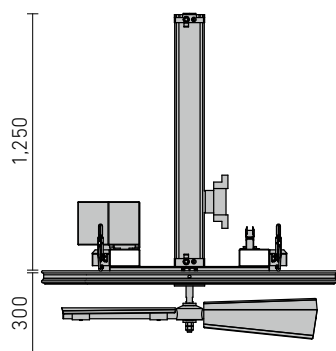

### Capacity

- To tank ø 1,000 mm 1,100 litres capacity
- To tank ø 1,200 mm 1,600 litres capacity
- To tank ø 1,400 mm 2,200 litres capacity
- To tank ø 1,400 mm 3,300 litres capacity
- To tank ø 1,600 mm 2,850 litres capacity
- To tank ø 1,600 mm 3,850 litres capacity
- To tank ø 1,800 mm 4,900 litres capacity
- To tank ø 2,000 mm 6,000 litres capacity

### Order No. Time / Interval regulation

- 46250
- 46260
- 46270
- 46270
- 46280
- 46280
- 46290
- 46300

### Order No. Manual

- 46310
- 46320
- 46330
- 46330
- 46340
- 46340
- 46350
- 46360

**Please note: installation space + 500 mm above tank incl. mobile plunger.**